

Seamless acoustic ceiling Installation guideline OWAplan⁹⁰

OWAconsult collection



1. Assembly tools required	4
2. General information	5
3. Installation requirements	7
3.1 Requirements prior to installation of the OWAplan ceiling	7
3.2 Requirements during installation of the OWAplan ceiling	7
3.3 Final inspection of the OWAplan ceiling	7
4. Grid, OWAplan board and plaster systems	8
4.1 Grid	8
4.2 OWAplan board	8
4.3 Plaster systems	8
4.3.1 OWAplan XS plaster system, white, ready to use	8
4.3.2 OWAplan XS plaster system, white, ready to mix powder	9
4.3.3 OWAplan color plaster system, ready to use	9
5. Installation of the grid without fire resistance	10
5.1 Plan view of substructure	10
5.2 Installation of angle profile no. 51/27	11
5.3 Comfort access flaps no. 8031/11 and no.8031/12	11
5.4 Mounting frame for fittings up to 2.5 kg	14
5.5 Expansion gaps	14
5.6 Installation of the OWAplan boards	15
5.7 Fixing points of the plate	16
5.8 Connection to wall, gypsum frieze, bulkhead and folded gypsum	17
5.9 Bevelled installation	18
5.10 Direct fixing	18
6. Installing fire resistant ceiling REI 60 under steel beam floors acc. to EN 13501-2.	19
6.1 Grid and grid spacing for fire resistant installation	19
6.2 Installation instructions for fire resistant version	20
6.2.1 Suspension depth	20
6.2.2 Tile screw spacing for drywall screws and countersunk washer no. 2027	20
6.2.3 Wall connection	20
6.2.4 Components	20
7. Material requirements and system components for your planning.	21
7.1 Material requirements per sqm for substructure	21
7.2 Board	21
7.3 Plaster system	22
8. Application instructions	23
8.1 Construction site conditions	23
8.2 Filling and sanding joints	23
8.3 Acoustic plaster OWAplan XS and color	23
8.3.1 Apply OWAplan XS plaster, white, ready to use	23
8.3.2 Apply OWAplan XS plaster, white, ready to mix	24
8.3.3 Apply OWAplan color plaster, coloured, ready to use	24
8.4 Plastering machines	25
8.4.1 Screw pump	25
8.4.2 Airless pump	25

1. Assembly tools required

1. Board lift
2. Sharp knife
3. Cordless screwdriver
4. Mixing paddle
5. Trowel
6. Wide spatula
7. Pencil
8. Scale
9. Screw pump
10. Airless pump
11. Nozzle 635
12. Sanding giraffe
13. Hand grinder
14. Humidity and temperature meter

Link to the processing video:

<https://www.owa.de/en/owaplan/>



Link to the image database:

<https://www.media.owa.de/>



2. General information

A seamless acoustic ceiling is a high-quality system that must meet both acoustic and aesthetic requirements at a high level. To meet these requirements, strict specifications must be observed during installation and coating. The quality of the ceilings depends largely on how the individual components are installed, as well as on the necessary preparatory measures and the conditions on the construction site. The work should be carried out under climatic conditions that correspond to those of the subsequent operating environment. This applies in particular to the preparation and execution of the ceiling connections and the coating, but also to the time afterwards. The better the indoor conditions before, during and after installation match the future conditions, the less likely it is that deformations or stresses will occur in the ceilings, thereby reducing the risk of undesirable consequential damage such as cracks, colour differences or loss of acoustic properties.

OWAplan is a special high-quality ceiling system whose appearance is largely determined by the installation of the grid and plaster system. Installing and covering this ceiling system requires appropriate experience and knowledge in seamless plastercovered ceilings.

OWA therefore offers a **training course on how to install an OWAplan ceiling**. The training course covers the entire process, from assembling the grid, fitting the mineral boards, taping and jointing, to the plaster system. If the installation of the grid and the mineral boards is not to be carried out by a certified coating company, detailed and extensive step by step instructions must be provided in advance by the responsible technical advisor or OWAplan technician. Training dates need to be arranged in good time with OWA. Since this is a certified building product training can only be provided if all system components being used are EN 13964, EN 14195 and EN 14566 certified.

Classification of fire behaviour as a building product OWAplan seamless acoustic ceiling has been classified as A2-s1,d0 - non-combustible in compliance with EN 13501-1 and is CE marked as a ceiling-KIT. The quantities to be applied as specified in the relevant test report and the system components listed there must be adhered to and applied. If other non-tested system components are used, the system characteristics of the OWAplan⁹⁰ building product cannot be guaranteed.

Acoustic performance

Seamless acoustic ceiling OWAplan incl. plaster coating

OWAplan⁹⁰

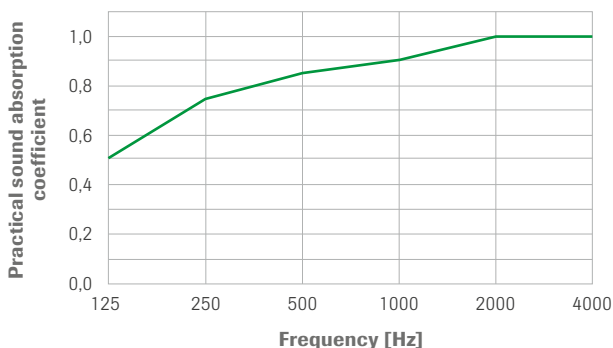

$$\alpha_w = 0.90, \text{NRC} = 0.90$$

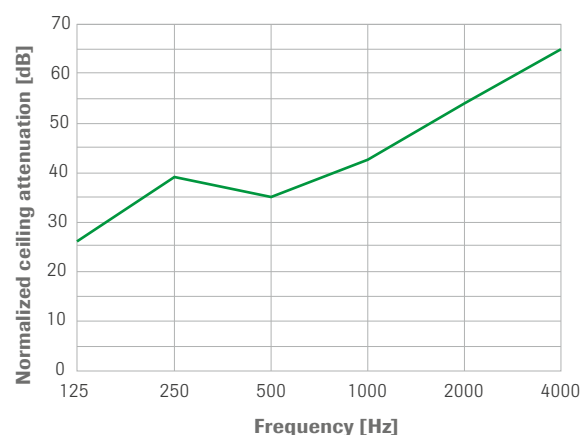

$$D_{n,f,w} = 40 \text{ dB}, \text{CAC} = 41 \text{ dB}$$

Labelling in accordance with the Construction Products Regulation (EU-CPR)

OWAplan has been tested and labelled in accordance with the Construction Products Regulation no. 305/2011. The requirement for a Declaration of Performance (DoP) is therefore satisfied for the grid, the mineral board and the plaster system. You can find the DoP number on the respective packaging.

Fixings

Ceilings and roofs:

Connection and fastening elements upper suspension: In order to be able to create a force-fit connection between the ceiling soffit or roof structure and the OWAconstruct suspension system, only approved fixings may be used. For anchorages in solid substrates, the relevant ETA (European technical approval) of the respective fixing must generally be observed in accordance with EN 13964.

Steel and solid concrete soffits:

The false ceiling hangers must be installed to the concrete soffit using building code-approved fixings. The fixing manufacturer's instructions must be adhered to. The respective valid approvals or the building code test certificates of the fixing elements (possibly pull-out tests) must be considered.

Roof decking with trapezoidal sheet metal:

Trapezoidal sheet metal roof decking usually has large spans. Due to wind pressure or suction effects, the roof could vibrate via the ceiling suspension, which will cause cracking in a monolithic sub-ceiling. Therefore, we do not recommend direct suspension of a sub-ceiling to trapezoidal sheet metal. A solution could be an independent auxiliary structure fixed to the metal roof. Suitable examples include OWA long-span beams type 6500.

Handling, transport and storage of the mineral boards

Panels may only be transported horizontally by two people. The panels must always be placed face up. Each panel has a cardboard interlayer for protection. Acoustic elements and accessories must be protected from moisture and stored in a frost-free place in the building. To protect the panels, it is recommended to store them in their packaging until installation.

Improper storage and/or the absorption of moisture can lead to deformation of the elements, which could adversely affect the final result. The materials must be given the opportunity to acclimatize before processing.

Safety

Ensure good ventilation at the workplace during installation and avoid inhaling dust. Avoid contact with your eyes and skin. For more information, refer to the safety data sheet.

Warranty

If the recommended installation instructions valid at the time of assembly are not followed, the warranty for the OWA system components will be voided.

3. Installation requirements

3.1 Requirements prior to installation of the OWAplan ceiling

- The installation area must be weatherproof, watertight and clean (no outdoor use).
- During installation of the ceiling system, the relative humidity must be between 40 % and 70 % and the temperature should be 10 - 30 °C, preferably 18 °C.
- Temperature and humidity should be kept as constant as possible. Significant and/or rapid fluctuations can lead to undesirable changes in shape, which can result in cracks.
- Sufficient ventilation must be provided during and after completion of the ceilings to promote drying. Do not blow warm or hot air directly onto the ceilings!
- System-compliant construction components in accordance with EN 13964, EN 14195 and EN 14566 must be used.
- All layout plans including the required fittings must be available prior to commencing work.
- All wall connections are to be executed in a flexible joint design.
- Existing building expansion joints are to be incorporated into the OWAplan ceiling.
- All fittings that may be required must be provided prior to installing the OWAplan boards. This requires coordination with drywall workers, electricians and other participating tradespersons.
- Taping and jointing and plaster coating must to be completed by a certified contractor only. The certificate needs to be verified during the tender phase ([refer to section 2](#)).
- Higher quality standards regarding surface properties, e.g. using a suspended ceiling in poor daylight or artificial light conditions, must be agreed in advance.
- Artificial lighting directed at the ceiling surface from below or from the side (e.g. spotlights, indirect lighting) is to be avoided. If this is not possible, the ceiling is to be sanded, filled and coated under the lighting conditions prevailing in subsequent use. Such extra quality standards for the surface are to be agreed in advance.
- For fire protection requirements, the design specifications according to the test certificate must be observed ([for further information see point 6., page 19](#)).

3.2 Requirements during installation of the OWAplan ceiling

- The installed ceiling system (substructure and OWAplan tiles) must be approved by the coating company prior to applying the plaster. Any re-working requested by the coating company must be carried out.
- Observe all specified drying times for the plaster system.
- Additionally suspend all fixtures from the raw ceiling.
- Daily record of room and outdoor temperature, as well as relative humidity during installation.
- If installation work is hindered by external influences for which the contractor is not responsible, or if installation conditions, drying times etc. specified in these installation instructions are deviated from, concerns must be made in writing to the client.

3.3 Final inspection of the OWAplan ceiling

When assessing the work carried out, the fact that the installation of the ceilings involves manual work must be taken into account. The final assessment of the evenness and surface condition may only be carried out in diffuse light and not in direct artificial light, e.g. from construction lamps. The visual inspection is carried out at a distance of 1 m from the surface. It is not possible to completely prevent joints from being visible; slight differences (even within the tolerance limits) may become visible in grazing light. Unusual lighting situations in the building must be discussed with the contractor in advance.

Tolerances for evenness between two measuring points: Distance 400 mm: < 1 mm; distance 1 m: < 2 mm

4. Grid, OWAplan board and plaster systems

4.1 Grid

Only the profile construction parts listed below or equivalent must be used. The specified grid spacings are to be observed. Deviations can negatively influence or change the subsequent appearance of the OWAplan ceiling.

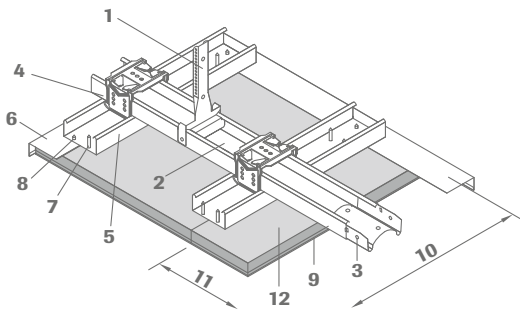

- 1 Nonius hanger C profile 60/27 acc. to EN 13964, spacing ≤ 1000 mm
- 2 Supporting grid C profile 60/27 acc. to EN 14195, spacing ≤ 1000 mm
- 3 Profile connector acc. to EN 13964
- 4 Cross connector or equivalent acc. to EN 13964
- 5 Tile grid C profile 60/27 acc. to EN 14195, spacing ≤ 400 mm
- 6 Wall angle. no. 51/27
- 7 Drywall screw 3.9 x 35 mm with fine thread acc. to EN 14566 and washer no. 2027, fixing distance ≤ 400 mm
- 8 Self-tapping screw no. 2024
- 9 Plaster system
- 10 Board width
- 11 Board length
- 12 OWAplan board

4.2 OWAplan board

OWAplan boards are mineral tiles with a glass fiber fleece laminated on the front side at the factory. This later determines the width that is filled with OWAplan Filler. The boards are fastened to the C profile construction using drywall screws 3,9 x 35 mm (fine thread) and a washer. The panel joints must be butt-jointed and sealed. A fabric tape (OWAplan Tape) is glued to the fleece-free edge before filling. The filling of the panel butt joints serves to create a homogeneous, airtight ceiling level (for further information, see [point 5.6, page 15](#) and [point 8.2, page 23](#)).

Building material class: A2-s1,d0 in accordance with EN 13501-1

Board sizes: 2400 x 1200 x 25 mm

Visible board side: fleece-laminated, white

Weight: 4.5 kg/m²

4.3 Plaster systems

4.3.1 OWAplan XS plaster system, white, ready to use

OWAplan Tape, textile tape

OWAplan Filler, reinforcing filler, ready to mix powder

OWAplan XS, acoustic plaster, white, ready to use, 0.2 mm grain thickness, can be applied using a screw or airless pump

4.3.2 OWAplan XS plaster system, white, ready to mix powder

OWAplan Tape, textile tape

OWAplan Filler, reinforcing filler, ready to mix powder

OWAplan XS, acoustic plaster, white, ready to mix powder, 0.2 mm grain thickness, application with airless pump possible

4.3.3 OWAplan color plaster system, ready to use

OWAplan Tape, textile tape

OWAplan Filler, reinforcing filler, ready to mix powder

OWAplan color, colored acoustic plaster, RAL/NCS-1950 shades, ready-to-use, 0.2 mm grain thickness, can be processed with a screw and airless pump

5. Installation of the grid without fire resistance

During installation, ensure that the support grid is mounted parallel to the incidence of daylight. Installation with C profiles and Nonius hangers with a max. grid spacing of 1000 mm for the C profiles. The first and last C profiles are to be installed with a max. grid spacing of 150 mm from the wall. The entire construction must be made level. The max. grid spacing of Nonius hangers from the wall is 250 mm. The max. grid spacing of the Nonius hangers to each other is 1000 mm. The C profiles are connected using profile connectors.

5.1 Plan view of substructure

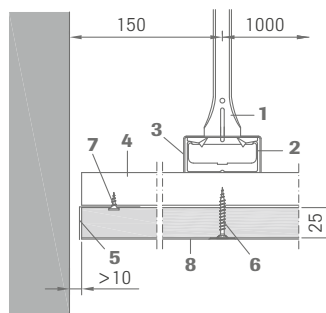
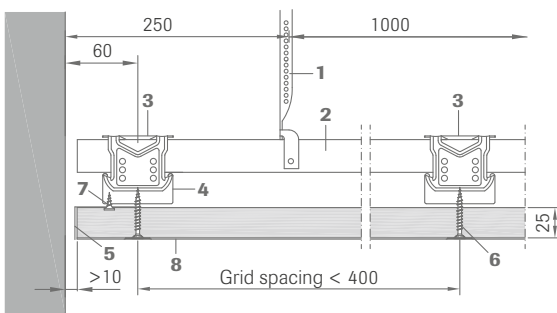
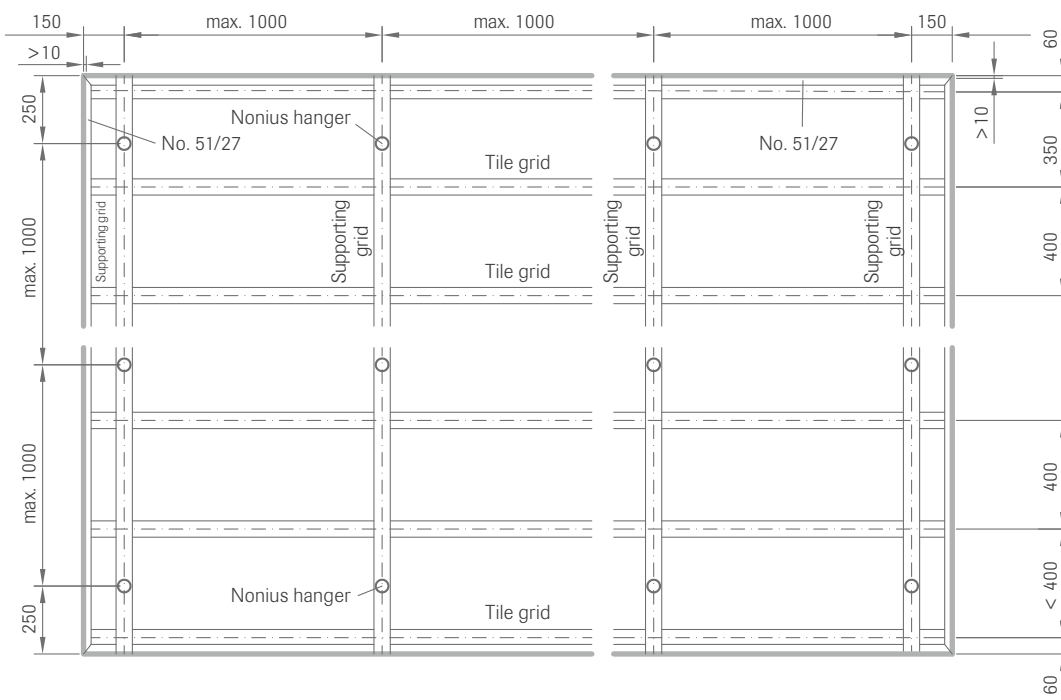

- 1 Nonius hanger acc. to EN 13964
- 2 C supporting grid
- 3 Cross connector
- 4 C tile grid
- 5 Angle no. 51/27
- 6 Drywall screw 3.9 x 35 mm and washer no. 2027
- 7 Self-tapping screw
- 8 Plaster system

Installation with C profiles at max. grid spacing of 400 mm. The first and last C profiles are to be installed with a max. grid spacing of 60 mm from the wall. Attachment to supporting grid using cross connector. The cross connector is first hooked under one side of the C profile so that both lugs engage in the curved edge of the C profile. The connector is only then clicked into the opposite bent edge of the C profile. The C profiles are connected using profile connectors.

5.2 Installation of angle profile no. 51/27

The circumferential and sliding wall connection to the C profiles of the tile grid is made with wall angle no. 51/27. Wall angle is fastened to the C profiles with self-tapping screws no. 2024 at a center distance of max. 400 mm. Distance wall angle from the wall ≥ 10 mm.

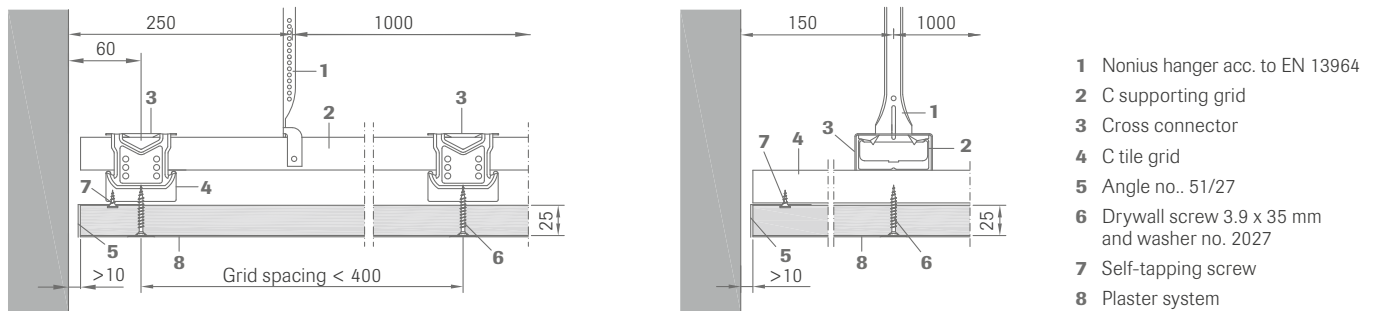

5.3 Comfort access flaps no. 8031/11 and no.8031/12

When installing a seamless OWAplan ceiling, access flaps are usually required.

No. 8031/11 (340 x 340 mm) for 25 mm OWAplan⁹⁰ boards, excl. OWAplan board
No. 8031/12 (540 x 540 mm) for 25 mm OWAplan⁹⁰ boards, excl. OWAplan board

Nonius hanger + extension for comfort access flap, 2 pcs /4 pcs per access flap.

The following points need to be considered:

- The exact location of the access board needs to be aligned to the grid of the suspended ceiling.
- The Nonius hangers must be installed according to the size and weight of the planned access flaps ([see ceiling plan](#)).
- The size of the ceiling opening must match the exterior dimension of the access flap to be installed.
- The access flaps need to be installed prior to board installation.
- When using access flap no. 8031/12, the C profile around the hatch needs to be removed. Two C profiles (length = 1000 mm) also need to be installed and suspended from the soffit ceiling ([see ceiling plan 540 x 540 mm](#)).
- The OWAplan⁹⁰ mineral board must be cut to the size of the inspection hatch on site before gluing with adhesive no. 99/24 into the lid of the inspection flap.

Ceiling plan view access flap 340 x 340 mm:

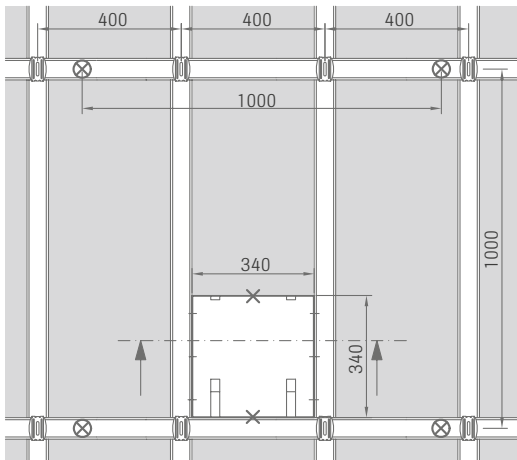

⊗ = 2 additional hangers acc. to EN 13964
+ safety pin acc. to EN 13964 (x 2)

⊗ = Nonius hanger acc. to EN 13964

Cross-section through access flap no. 8031/11:

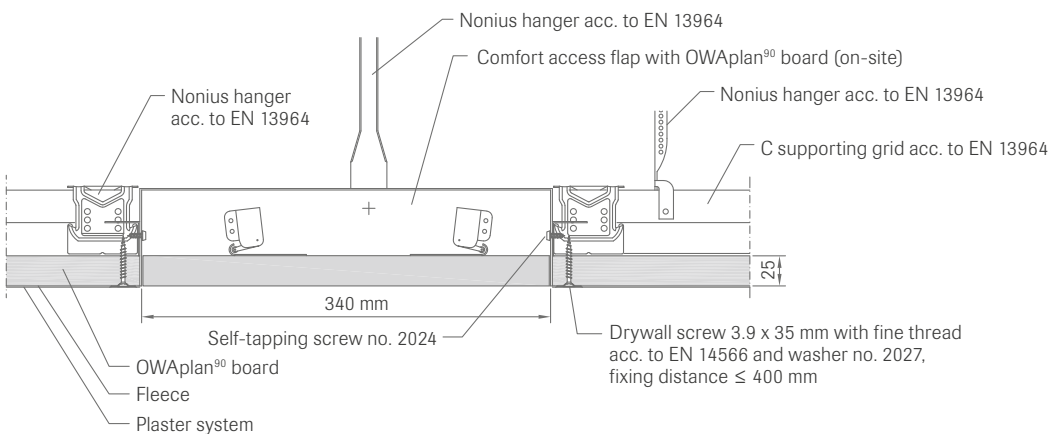

Ceiling plan view access flap 540 x 540 mm:

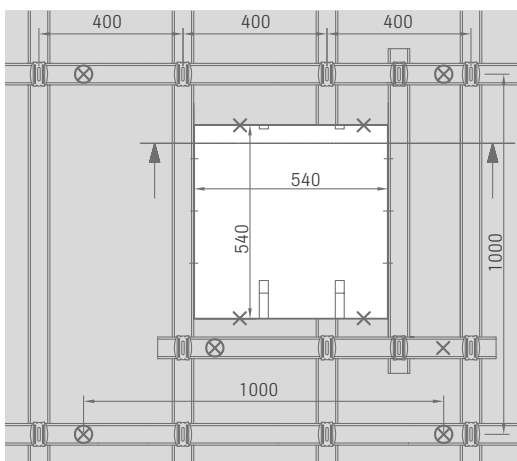

Additional C supporting grid acc. to EN 14195, length = 1000 mm,
with cross connector acc. to EN 13964, attached to the C tile grid
acc. to EN 14195.

⊗ = 4 additional hangers acc. to EN 13964
+ safety pin acc. to EN 13964 (x 2)

⊗ = Nonius hanger acc. to EN 13964

When installing access panel no. 8031/11 (540 x 540 mm), a change must be made. Cut the primary C profile and install additional profiles and Nonius hangers according to the drawing.

Cross-section through access flap no. 8031/12:

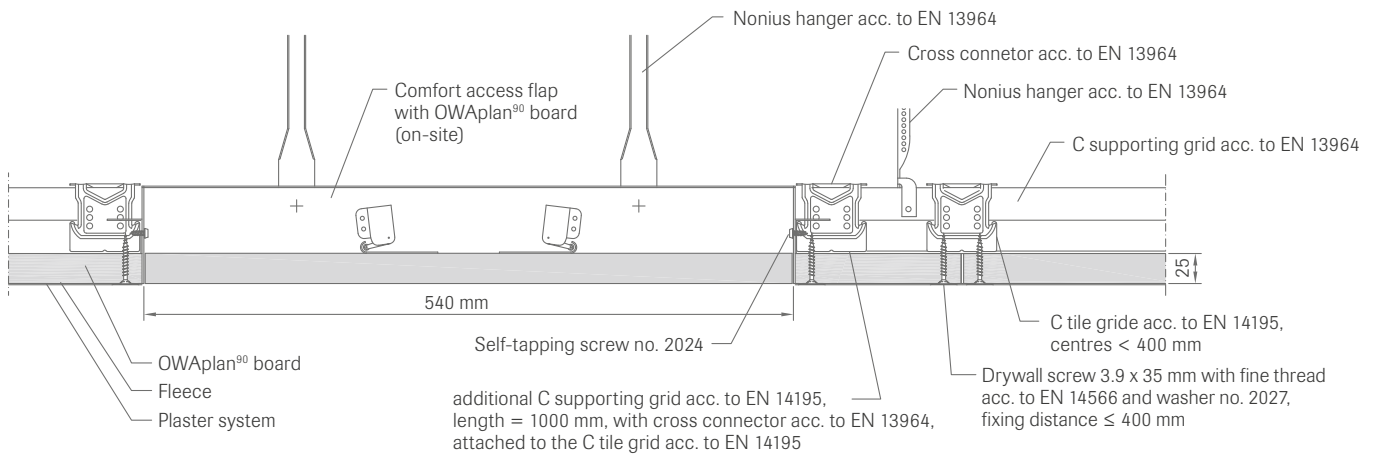

The access flap is inserted sideways into the opening and then aligned and fixed in place onto the C profiles using six screws. Fine adjustment can be made at the hinge fasteners and the locking mechanism by unscrewing the screws and vertically sliding along the slot hole. The inspection flap must be assembled by the customer and incorporate the OWAplan board sprayed with the plaster system coating according to manufacturer's instructions. After coating, the flap needs to be opened, cleaned, and made accessible.

The flap is **opened** by pressing upwards on the side of the access part and immediately lowering it. The flap is closed by lightly pressing it. An audible click triggers the closing mechanism. We strongly recommend opening and closing the hatch only with clean installation gloves.

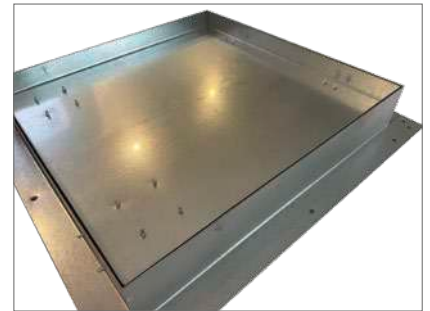

5.4 Mounting frame for fittings up to 2.5 kg



When installing downlights, mounting frame no. 8069/6 (two-part) is to be used. One mounting frame is required for each downlight. The frames must be placed with their edges on the C profiles. Spacing between the frames depends on the diameter of the chosen downlight.

Ensure that the clamping device of the downlight later rests on the frame and that the mounting frame does not project beyond the edge of the hole. The opening for the downlight can be created with radius cutter no. 99/16. The size is to be adapted to the diameter of the downlight. Install before mounting the board!

It is possible to use the mounting frame for rectangular or square installations. In this case, please use the straight contour of the two individual parts of the frame.

Downlights each weighing 250 g - 2.5 kg require installation with a frame. Downlights weighing more than 2.5 kg each require additional suspension from the soffit.

Electrical wiring is to be carried out before sealing the ceiling. Cables are to be kept to the length required. Light functioning is to be checked prior to installation because later modifications will not be possible.

5.5 Expansion gaps

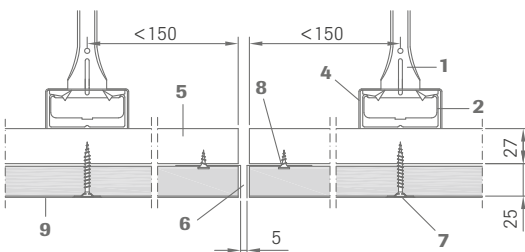

5.6 Installation of the OWAplan boards

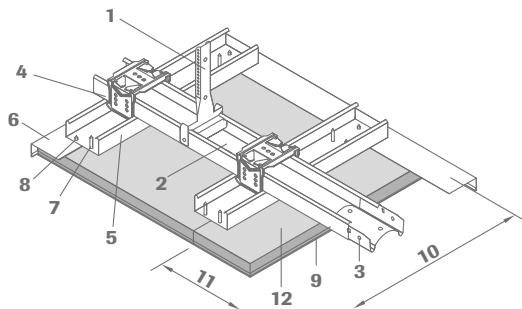

- 1 Nonius hanger acc. to EN 13964, spacing ≤ 1000 mm
- 2 Supporting grid C profile 60/27 acc. to EN 14195, spacing ≤ 1000 mm
- 3 Profile connector acc. to EN 13964
- 4 Cross connector or equivalent acc. to EN 13964
- 5 Tile grid C profile 60/27 acc. to EN 14195, spacing ≤ 400 mm
- 6 Wall angle. no. 51/27
- 7 Drywall screw 3.9 x 35 mm with fine thread acc. to EN 14566 and washer no. 2027, fixing distance ≤ 400 mm
- 8 Self-tapping screw no. 2024
- 9 Plaster system
- 10 Board width
- 11 Board length
- 12 OWAplan board

The panels must be installed using a panel lift. Important during installation: Pressure points caused by the panel lift must be avoided. Position the boards directly onto the profiles over the entire surface and screw them to the grid using a torque driver to create a stable connection with the substrate. The drywall screws 3.9 x 35 mm with fine thread and countersunk washer no. 2027 must be installed at a maximum center distance of 400 mm (fleece should not crack). The custom washer should embed slightly into the fleece surface but remain flush. The screws are always screwed to the C profiles from the center of the board outwards.

The boards should be staggered with an offset of at least 800 mm. The longitudinal edges of the boards should always be installed in the direction of daylight incidence (main direction).

Do not draw any lines on the fleece with a pencil or similar. They can't be removed after completion and will show through the plaster coating. The use of a laser is recommended.



Tip: Using a helmet to support boards during installation may produce indentations which will be visible later. This is therefore to be avoided. The boards need to be treated with great care.



Drywall screw 3.9 x 35 mm and countersunk washer no. 2027

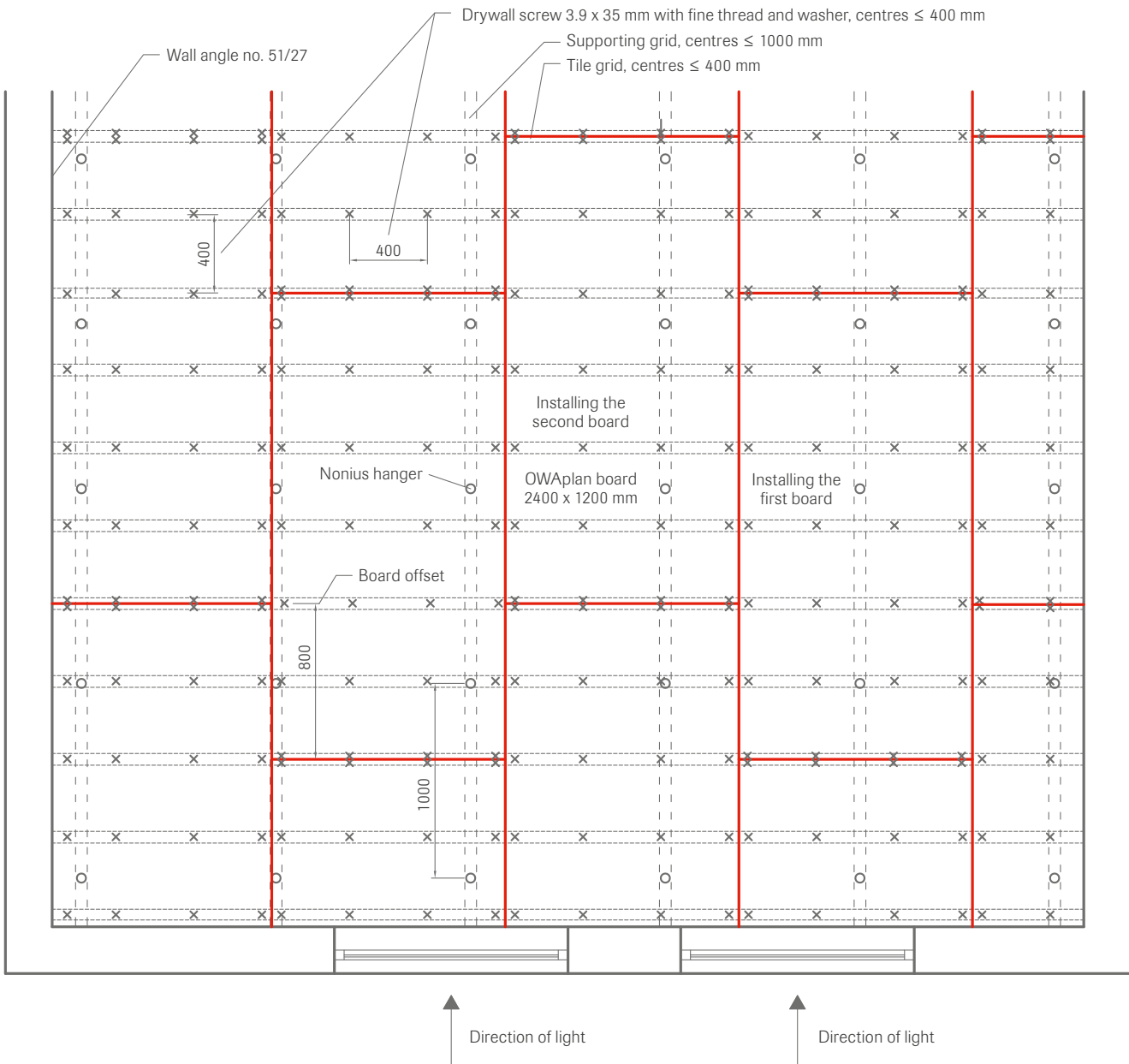

5.7 Fixing points of the plate

Insert drywall screw 3.9 x 35 mm with fine thread according to EN 14566 and countersunk washer no. 2027 at a fixing distance of 400 mm. The screws with washer are easy to countersink without damaging the fleece. Edge distance 15 - 20 mm for the screws in the butt joint area of the panels. Screw spacing in the wall connection from the wall profile 55 mm.

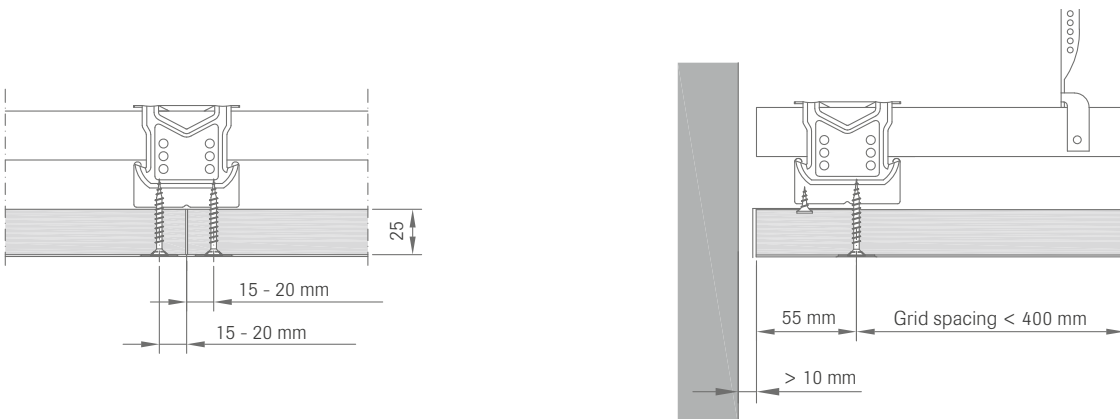

5.8 Connection to wall, gypsum frieze, bulkhead and folded gypsum

Connecting OWAplan to gypsum bulkheads:

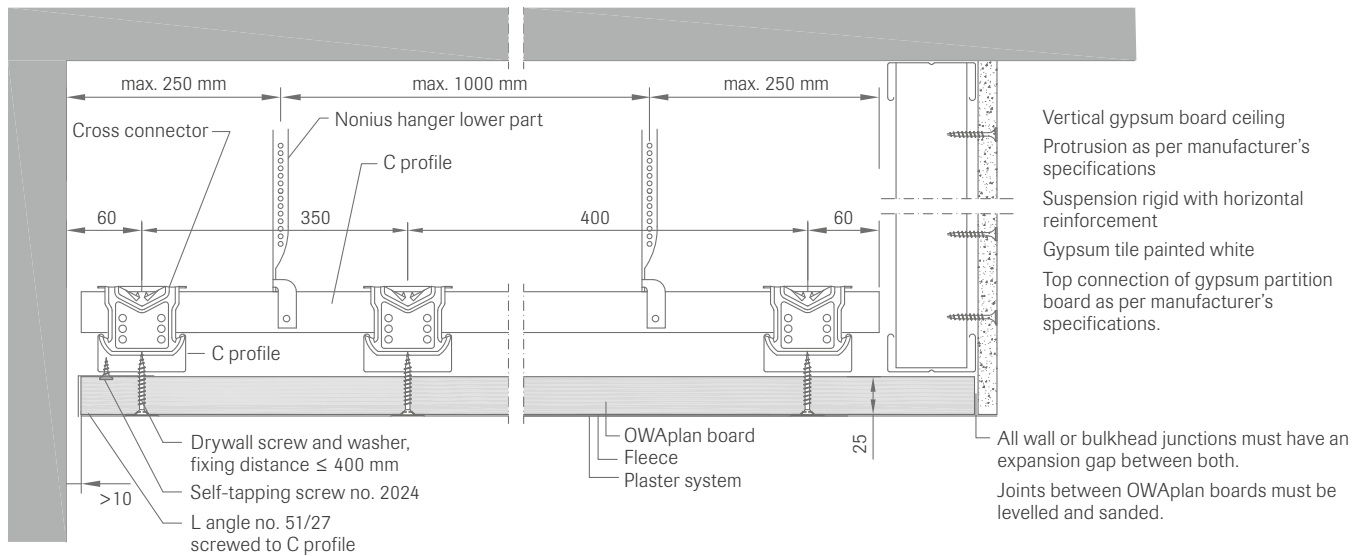

Connecting OWAplan to gypsum frieze or folded gypsum:

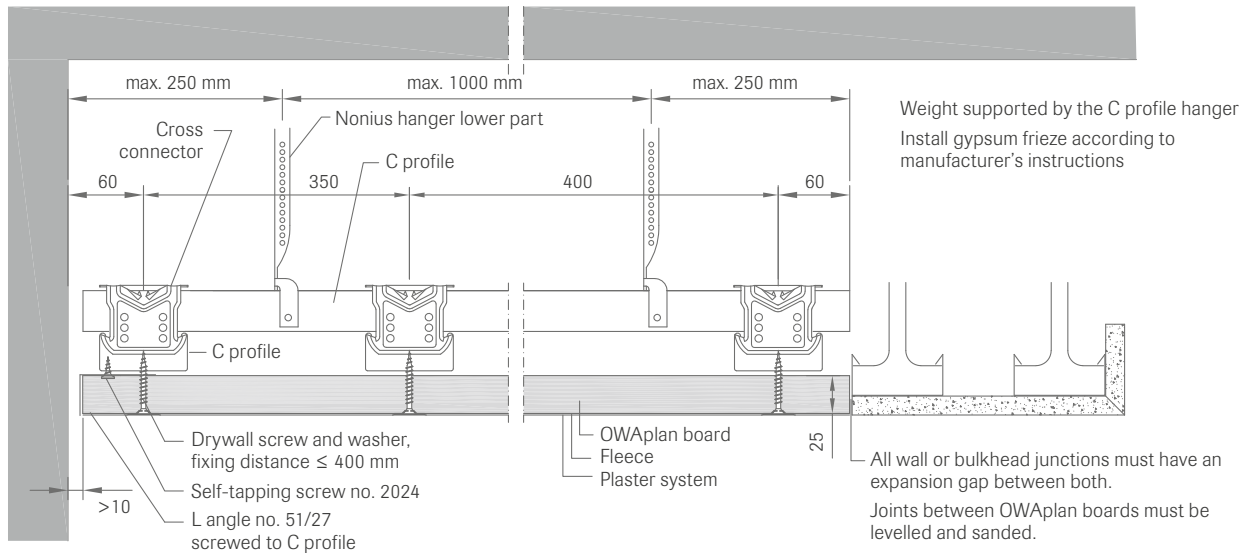

5.9 Bevelled installation

Bevelled installation longitudinal section:

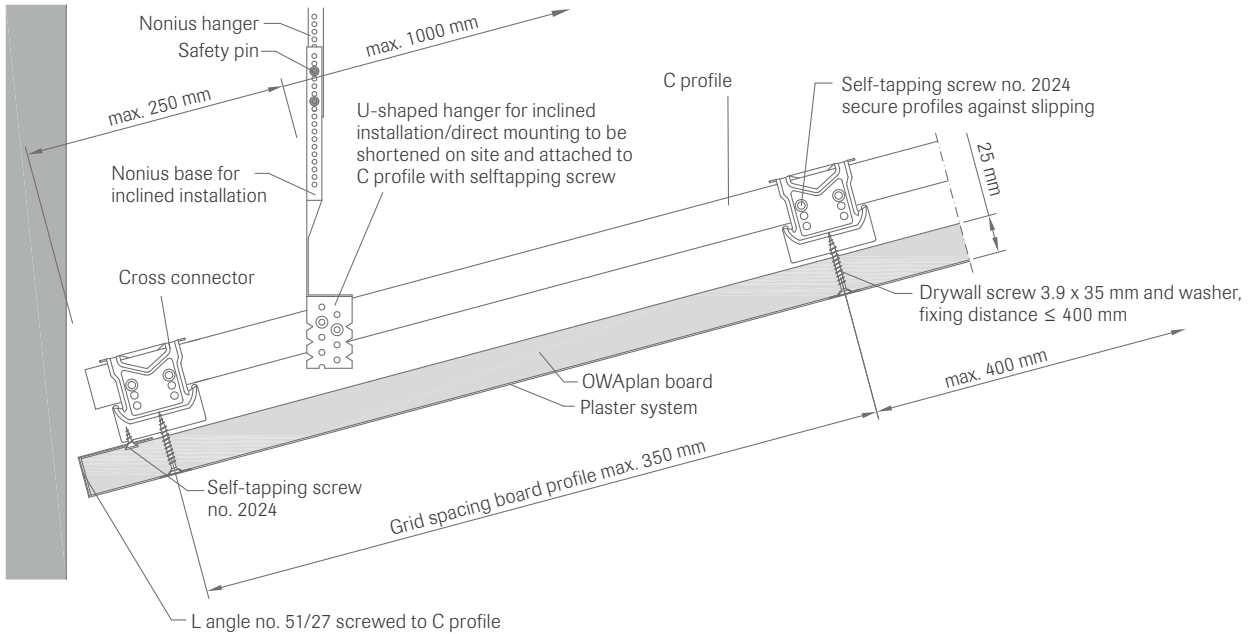

5.10 Direct fixing

Minimum suspension depth approx. 80 - 90 mm from the raw ceiling

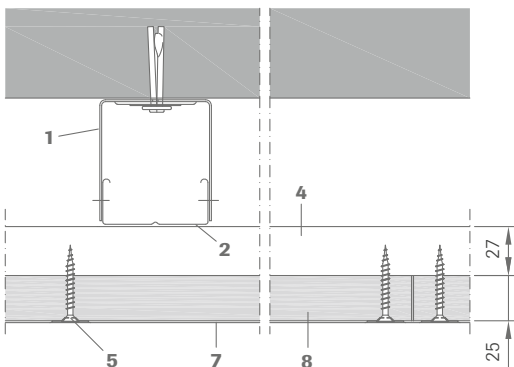

- 1 U-hanger acc. to EN 13964 for inclined installation/direct mounting, to be shortened on-site, spacing ≤ 1000 mm.
- 2 Supporting grid C profile 60/27 acc. to EN 14195, spacing ≤ 1000 mm
- 3 Cross connector or equivalent acc. to EN 13964
- 4 Tile grid C profile 60/27 acc. to EN 14195, spacing ≤ 400 mm
- 5 Drywall screw 3.9 x 35 mm with fine thread acc. to EN 14566 and washer no. 2027, fixing distance ≤ 400 mm
- 6 Angle no. 51/27
- 7 Plaster system
- 8 OWAplan board

6. Installing fire resistant ceiling REI 60 under steel beam floors acc. to EN 13501-2

Only profile parts listed below are to be used. Specifications and grid spacings in the test certificate are to be observed.

6.1 Grid and grid spacing for fire resistant installation

- Minimum suspension depth ≥ 250 mm
- Nonius hangers according to EN 13964 – max. grid spacing = 1000 mm, maximum grid spacing from the outer boundary = 250 mm
- C profile according to EN 14195 (support grid), 60 x 27 x 0.6 mm – max. grid spacing = 1000 mm, maximum grid spacing from the outer boundary = 150 mm.
- C profile according to EN 14195 (tile grid), 60 x 27 x 0.6 mm – max. grid spacing = 400 mm, maximum grid spacing from the outer boundary = 50 mm
- Cross connector or equivalent acc. to EN 13964
- Profile connector acc. to EN 13964
- Drywall screw 3.9 x 35 mm with fine thread acc. to EN 14566 and countersunk washer no. 2027, max. grid spacing = 150 mm (spacing tile grid max. 400 mm)
- For a butt joint junction at a wall, without angle profile no. 51/27, the maximum permissible expansion gap is ≤ 3 mm

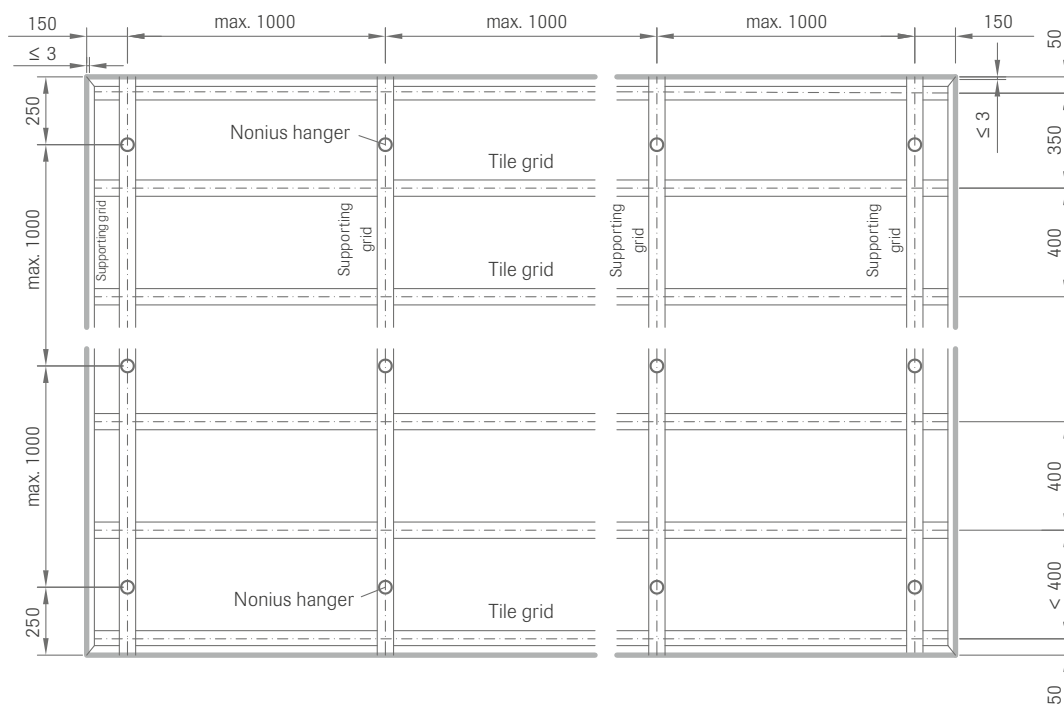

6.2 Installation instructions for fire resistant version

The installation of the fire resistant version of the ceiling must be carried out according to the test certificate.

6.2.1 Suspension depth

Minimum suspension depth ≥ 250 mm.

6.2.2 Tile screw spacing for drywall screws and countersunk washer no. 2027

For the fire safety, the spacing for the fine-thread drywall screws 3,9 x 35 mm according to EN 14566 and countersunk washer no. 2027 is reduced to a maximum of 150 mm (spacing of panel grid max. 400 mm).

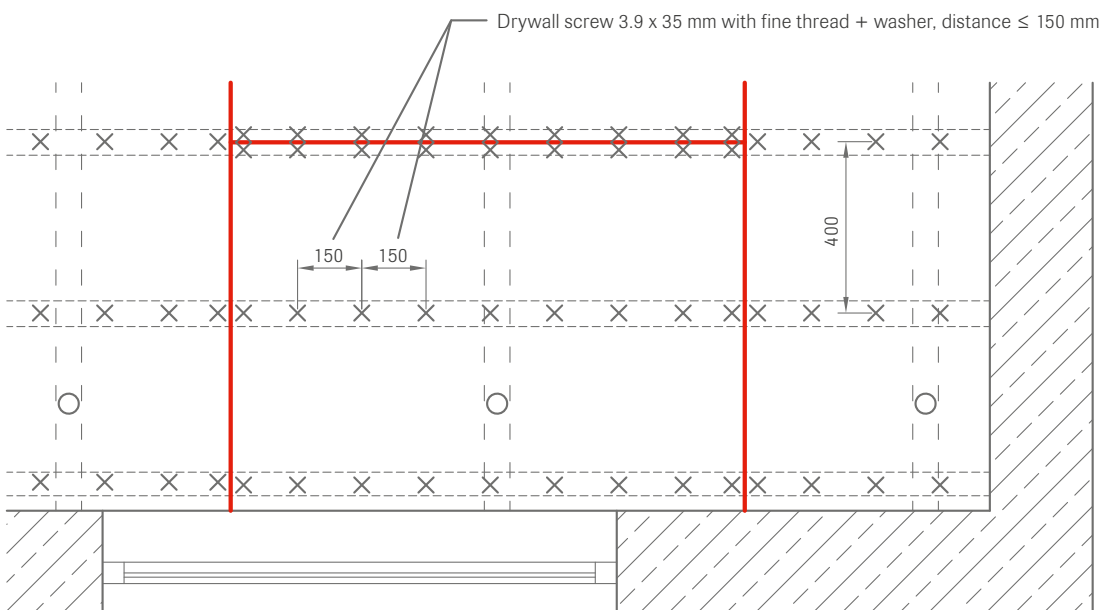

6.2.3 Wall connection

To meet fire protection requirements, open shadow gaps are not permitted. The boards must be butt-jointed to the outer boundary without angle profile.

6.2.4 Components

All components – e.g. integrated light fixtures, downlights, inspection hatches, etc. – must be equipped on the rear with OWA fire boxes. Installation in accordance with test certificate.

OWA fire boxes are made from 15 mm MINOWA® fire protection boards, kit no. 00082673, and must be assembled on site ([see leaflet 9501 e](#)).

7. Material requirements and system components for your planning

Weights per m² (recommended values):

Grid weight approx. 2.5 kg/m² and approx. 4.5 kg/m² for OWAplan⁹⁰ board

7.1 Material requirements per sqm for substructure

No.	Description	per m ²
Purchase via specialised trade	Nonius hanger acc. to EN 13964 for C profile 60/27 (upper and lower part), maximum load: 0.40 kN	1 pce
	Safety pin	2 pcs
	U-shaped hanger acc. to EN 13964 for inclined /direct mounting	1 pce
	Nonius base acc. to EN 13964 for inclined Installation	1 pce
	C profile 60/27, 4000 x 60 x 27 x 0.6 mm acc. to EN 14195	3.5 m
	Cross connector or equivalent for C profile 60 x 27 mm acc. to EN 13964	2.5 pcs
	Profile connector for C profile 60 x 27 mm acc. to EN 13964	0.9 pce
	Drywall screw 3.9 x 35 mm with fine thread acc. to EN 14566* ¹	10 pcs 22 pcs for fire safety version
	2027 Countersunk washer* ¹	10 pcs 22 pcs for fire safety version
	2024 Self-tapping screw for no. 51/27	2.5 pcs/m, not applicable for fire protection
51/27	Angle profile for 25 mm OWAplan boards height: 52 mm, width: 27 mm, thickness: 0.7 mm, length: 3000 mm, visible side: white	dependent on project, not applicable for fire protection
51/27-O	Curved angle profile in m for 25 mm OWAplan ⁹⁰ boards	dependent on project, not applicable for fire protection
51/27-O	Angle profile column semi-circles up to Ø = 1500 mm, as a piece, for 25 mm OWAplan ⁹⁰ boards	dependent on project, not applicable for fire protection
8069/6	Mounting frame	dependent on project
8031/11* ²	Access flap 340 x 340 mm + no. 17/81 for 25 mm OWAplan ⁹⁰ boards	dependent on project
8031/12* ²	Access flap 540 x 540 mm + no. 17/81 for 25 mm OWAplan ⁹⁰ boards	dependent on project
99/24	Glue for access flap	dependent on project

*¹ The number of drywall screws and washers is an average value. The number of screws varies depending on the section of the ceiling concerned.

*² All inspection hatches excluding OWAplan⁹⁰ board. The OWAplan mineral board must be trimmed to the size of the inspection flap on site and glued in with adhesive no. 99/24.

7.2 Board

	OWAplan ⁹⁰
Part No.	00085563
Width	1200 mm
Length	2400 mm
Thickness	25 mm
Weight per board	13 kg
Weight per m ²	4.5 kg
Weight per sales unit	405.44 kg
m ² per board	2.88 m ²
Quantity per sales unit	32
Material type	mineral tile
NRC-value	0.95
α _w -value	0.95
Building material class	A2-s1,d0 acc. to EN13501-1
Board surface	fleece laminated. white
Storage	dry
Site condition	> 10 °C
Relative humidity	max. 70 %
Fleece free edge	30 mm

7.3 Plaster system



Description	OWAplan-Filler no. 2015	OWAplan Color plaster no. 2025	OWAplan XS plaster no. 2018	OWAplan XS plaster no. 2020
Part No.	00084275	project based	00084278	00093200
Material type	dry goods	wet goods	dry goods	wet goods
Color	-	RAL/NCS-1950 color shades	white (similar to RAL 9016)	white (similar to RAL 9003)
Weight per sales unit	7.5 kg	15 kg	7.5 kg	15 kg
Sales unit	bucket with bag	bucket	bucket with bag	bucket
Shelf life	24 months	18 months	24 months	18 months
Storage	frost-free, cool	frost-free, cool	frost-free, cool	frost-free, cool
Processing with screw pump	-	yes	no	yes
Processing with airless pump	-	yes	yes	yes
Material requirement with screw pump*1	not possible	approx. 2.1 kg/m ²	not possible	approx. 2.1 kg/m ²
Material requirement with airless pump*1	not possible	approx. 1.5 kg/m ²	approx. 0.7 kg powder/m ²	approx. 1.5 kg/m ²
Range per bucket*1 approx.	60 m ²	screw pump: 7 m ² airless pump: 10 m ²	11 m ²	screw pump: 7 m ² airless pump: 10 m ²
Mixing ratio	1 l water for 1.5 kg powder 5 l water for 7.5 kg powder 0.67 l water for 1 kg powder	ready to use	1 l water for 1.6 kg powder 5 l water for 7.5 kg powder 0.63 l water for 1 kg powder	ready to use
Processing time	approx. 60 minutes	-	approx. 120 minutes	-
Maturing time	approx. 15 min	stir up	approx. 15 minutes	stir up
Processing conditions*2	+10 °C up to +30 °C, 40 - 70 % RH	+10 °C up to +30 °C, 40 - 70 % RH	+10 °C up to +30 °C, 40 - 70 % RH	+10 °C up to +30 °C, 40 - 70 % RH
Drying time*3	1. layer: 4 hours 2. layer: 12 hours	1. layer: 12 hours 2. or 3. layer: 4 hours	1. layer: 12 hours 2. or 3. layer: 4 hours	1. layer: 12 hours 2. or 3. layer: 4 hours
Filler width	max. 100 mm	-	-	-
Spray distance to ceiling	-	700 mm	700 mm	700 mm
OWAplan Tape, no. 2016, textile tape, 90 m roll (part No. 00084276)	approx. 1.3 m/m ²	-	-	-
Plaster applicator	-	STROBOT 305 RSD Graco Mark VII or X	Graco Mark VII or X	STROBOT 305 RSD Graco Mark VII or X

*1 Material consumption including overspray must be maintained in order to fulfill the acoustic values

*2 Temperature and humidity should be kept as constant as possible. Significant and/or rapid fluctuations can lead to undesirable changes in shape, which can result in cracks.

*3 Depending on the room climate, drying times must be checked

8. Application instructions

8.1 Construction site conditions

- During the coating of the ceiling system, the relative humidity must be between 40 % and 70 % and the temperature should be 10 - 30 °C, preferably 18 °C.
- Temperature and humidity should be kept as constant as possible. Significant and/or rapid fluctuations can lead to undesirable changes in shape, which can result in cracks.
- Room temperature increases should be gradual with a maximum of 3 °C in 24 hours.
- Sufficient ventilation must be ensured during and after completion of the ceilings to promote drying. Do not blow warm or hot air directly onto the ceilings!
- The better the indoor conditions before, during and after installation match the future conditions, the lower the risk of deformations, cracks or color deviations.

8.2 Filling and sanding joints

Apply OWAplan Tape (no. 2016) to the board butt joints. Then apply the first layer of OWAplan Filler (no. 2015) to the 60 mm fleece free joints. The screws and washer must also be filled. Drying time approx. 4 hours depending on room climate. Subsequently, apply a second layer of filler so the surface is flat. Maximum filler width 100 mm. (Attention: Excessive filled surfaces can reduce the absorption properties of the ceiling boards.)

Sand the ceiling surface after 12 hours drying time at the earliest (depending on the room climate). Existing, coarse unevenness in the ceiling surface with a sanding giraffe, fine unevenness can be sanded with a hand sander. We recommend a sanding giraffe with dust extraction and 150 or 180 grit sandpaper. The surface should be smooth (no raised or hollow patched areas) and free of tool marks and/or grooves.

8.3 Acoustic plaster OWAplan XS and color

8.3.1 Apply OWAplan XS plaster, white, ready to use

OWAplan XS plaster can be processed with a screw pump and an airless pump.

Processing with the screw pump:

Stir OWAplan XS plaster (ready to use) with a mixing paddle. Apply the first layer by spraying and allow it to dry for at least 12 hours. Spray the second layer and let it dry (at least 4 hours – depending on room temperature and relative humidity). Then, apply the third layer. The recommended spraying distance to the ceiling is approximately 70 cm. Smaller distances will result in a cloudy and coarser spray pattern, while larger distances will produce a finer spray pattern but also lead to higher material loss.

Processing with the airless pump:

Spray the first layer of OWAplan XS plaster and allow it to dry for at least 12 hours. Spray the second layer and let it dry (at least 4 hours – depending on room temperature and relative humidity). Then, apply the third layer. The recommended spraying distance to the ceiling is approximately 70 cm. Smaller distances will result in a cloudy and coarser spray pattern. Larger distances will produce a finer spray pattern but also lead to higher material loss.

For more information on the pumps, see section [8.4 Plastering machines](#)

8.3.2 Apply OWAplan XS plaster, white, ready to mix

Mix OWAplan XS plaster (powdered material) in a bucket with clean, cold water using a mixing paddle. Stir the plaster again after 5 minutes and let it swell for 15 minutes.

Processing with the airless pump:

Spray the first layer of OWAplan XS plaster and allow it to dry for at least 12 hours. Spray the second layer and let it dry (at least 4 hours – depending on room temperature and relative humidity). Then, apply the third layer.

The recommended spraying distance to the ceiling is approximately 70 cm. Smaller distances will result in a cloudy and coarser spray pattern. Larger distances will produce a finer spray pattern but also lead to higher material loss.

For more information on the pumps, see section [8.4 Plastering machines](#)

8.3.3 Apply OWAplan color plaster, coloured, ready to use

OWAplan color plaster can be processed with a screw pump and an airless pump.

Processing with the screw pump:

Stir OWAplan color plaster (ready to use) with a mixing paddle. Spray the first layer and let it dry for at least 12 hours. Spray the second layer and let it dry (at least 4 hours – depending on room temperature and relative humidity). Then, apply the third layer. The recommended spraying distance to the ceiling is approximately 70 cm. Smaller distances will result in a cloudy and coarser spray pattern. Larger distances will produce a finer spray pattern but also lead to higher material loss.

Depending on the shade, the number of layers differs. Darker shades are sprayed in a total of 4 layers, while lighter shades require only 3 layers.

Processing with the airless pump:

Spray the first layer of OWAplan color plaster and allow it to dry for at least 12 hours. Spray the second layer and let it dry (at least 4 hours – depending on room temperature and relative humidity). Then, apply the third layer. The recommended spraying distance to the ceiling is approximately 70 cm. Smaller distances will result in a cloudy and coarser spray pattern. Larger distances will produce a finer spray pattern but also lead to higher material loss.

Depending on the shade, the number of layers differs. Darker shades are sprayed in a total of 4 layers, while lighter shades require only 3 layers.

For more information on the pumps, see section [8.4 Plastering machines](#)

8.4 Plastering machines

Before using the plastering machine, review all safety, operating, and maintenance information provided by the manufacturer. Clean and rinse the plastering machine with water before use.

8.4.1 Screw pump

The required plastering machine is a screw pump. The required delivery rate must be between 4 to 8 liters per minute. The recommended model is STROBOT 305 RSD.

In addition, a compressor is required with a delivery rate of at least 455 liters per minute and a pressure of 10 bar. Since the pressure is not constant during the coating process, the delivery rate is the most important factor. The recommended model is STROCOMP 865.

The diameter of the nozzle in the spray gun must be between 4 - 5 mm. The smaller the diameter of the nozzle, the finer the plaster structure, but the higher the risk of clogging the nozzle.



Plaster material	Pressure (Compressor)	Delivery rate (Compressor)	Delivery rate (Screw pump)	Nozzle (Diameter)
OWAplan XS and color, ready to use	≈10 bar	mind. 455 l/min	4 - 8 l/min	5 mm

8.4.2 Airless pump

The required plastering machine is an airless pump. It must be capable of building up a pressure of at least 200 bar. In smaller rooms, the pressure should be reduced accordingly to ensure a homogeneous surface spray.

The recommended models are Graco Mark VII or Mark X with the Graco TexSpray Heavy Duty spray gun and the 635 nozzle.



Plaster material	Pressure (Airless pump)	Nozzle	Recommended airless pump	Recommended spray gun
OWAplan XS and color, ready to use OWAplan XS, ready to mix	≈200 bar	635	Graco MARK VII and X	Graco TexSpray HeavyDuty

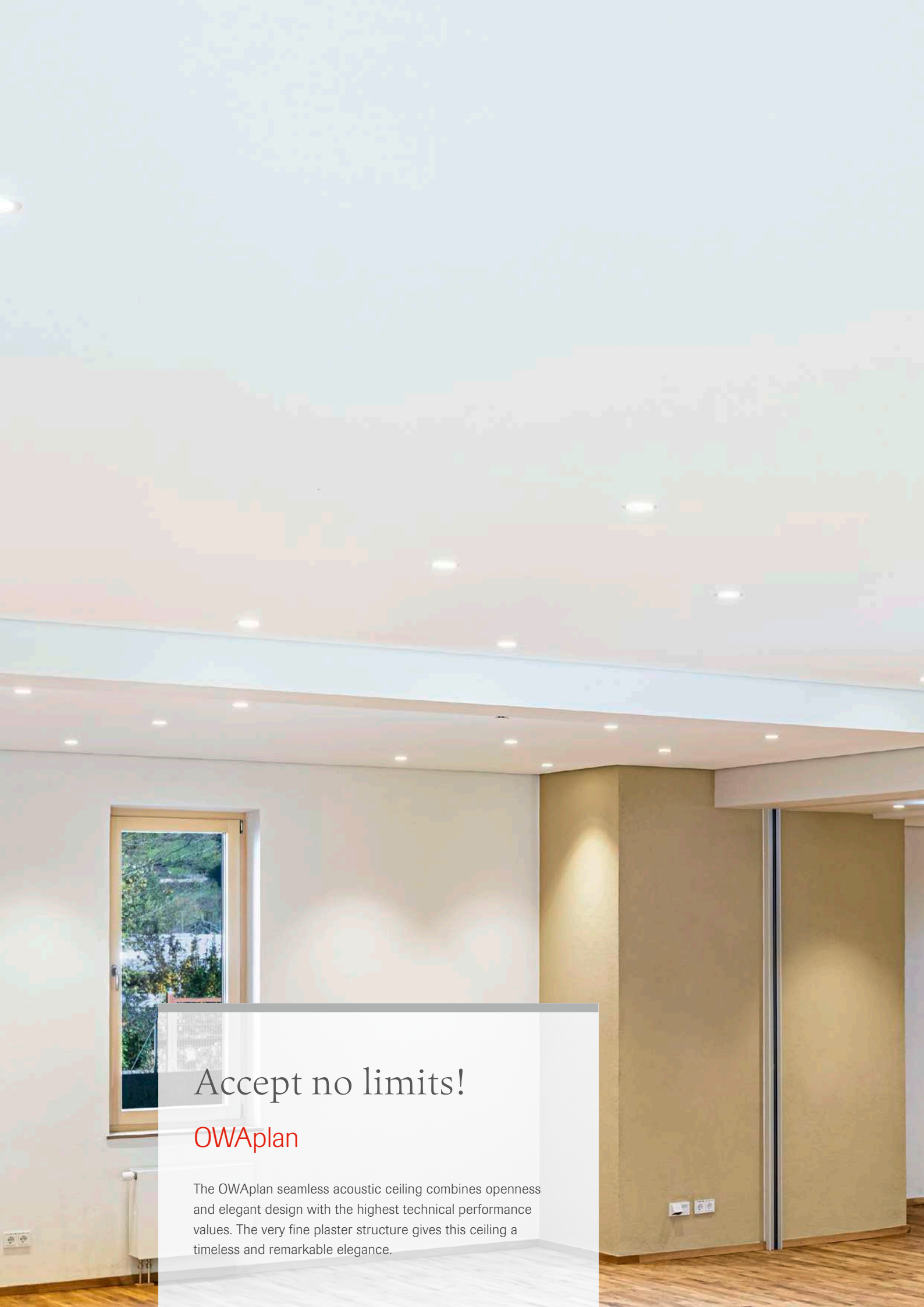

Accept no limits!

OWAplan

The OWAplan seamless acoustic ceiling combines openness and elegant design with the highest technical performance values. The very fine plaster structure gives this ceiling a timeless and remarkable elegance.





Certified Management Systems

Product warranties

The information provided in this leaflet is based on the standards and data available at the time of publication. Any performance, warranties or guarantees provided, expressed or implied, are subject to the exclusive use of OWA components and the installation of those components in accordance with our recommendations. Failure to adhere to these conditions will result in the invalidation of any performance claims, warranties or guarantees and rejection of any liability. OWA reserves the right to make any technical improvements to the products, systems or services without prior notice. **All goods and services are supplied in accordance with our current Terms and Conditions of Sale.** Subject to alterations!



The information in this brochure is up-to-date at the time of publication. Subject to alterations. Please contact our OWAconsult team for specific advice. Our experts will be happy to answer your questions using the following contact details: tel: +49 9373 201-444 or e-mail: info@owaconsult.de

Odenwald Faserplattenwerk GmbH
Dr.-F.-A.-Freundt-Straße 3 | 63916 Amorbach | Germany
tel +49 9373 201-0 | info@owa.de
www.owa-ceilings.com